



Yamarin Cross 64 Bow Rider

User manual

FOREWORD

Congratulations on choosing a Yamarin Cross boat!

This manual will familiarise you with the features of your new boat and help with its care and maintenance. It has been written to help you learn to handle your boat safely and avoid any problems. Make sure that you have received manuals for all equipment fitted on your boat. Supplement this manual with the specifications and manuals of equipment you purchase later for your boat. Space has been left for your own notes at the end of the manual. Please read this manual carefully and familiarise yourself with the craft before using it.

If this is your first craft, or you are changing to a type of craft you are not familiar with, please ensure that you obtain sufficient handling and operating experience before 'assuming command' of the craft. This is highly important for your own comfort and safety. Your dealer or national sailing association or yacht club will be happy to advise you of local boating schools or competent instructors.

This user manual is not a detailed maintenance or troubleshooting guide. In case of difficulty please contact the dealer. Always use qualified and competent people for the maintenance, repair and modification of the boat. Modifications that may affect the safety characteristics of the craft must be assessed, executed and documented by competent people. The manufacturer is not responsible for modifications they have not approved.

Always keep your boat in a good condition and be aware that the boat requires maintenance and servicing. Any craft, no matter how strong it may be, can be severely damaged if not used properly. Always adjust the speed and direction of the craft to prevailing weather conditions.

We wish you enjoyable and relaxing times on board your Yamarin Cross boat!

Inha Works Ltd.
Hahdenniementie 2
21120 Raisio
Finland

www.yamarin.com

Please keep this manual in a secure place, and hand it over to the new owner if you sell the craft.

Table of contents

1 General	6
1.1 Declaration of conformity	7
2 Definitions	9
3 Warranty	10
4 Before use	11
4.1 Registration	11
4.2 Insurance	11
4.3 Training	11
5 Characteristics and use of your boat	12
5.1 General	12
5.2 Basic data	12
5.3 Maximum recommended number of passengers:	14
5.4 Loading	15
5.5 Engine and propeller	16
5.6 Prevention of water incursion and stability	16
5.6.1 Hull and deck through fittings and closing valves	16
5.6.2 Stability and buoyancy	19
5.7 Preventing fires and explosion hazards	19
5.7.1 Refuelling	19
5.7.2 Fire protection	19
5.8 Main power switch and fuses	21
5.9 Operation	22
5.9.1 Controls	22
5.9.2 Emergency switch	22
5.9.3 Gearshift and throttle	23
5.9.4 Adjusting of trim angle	23
5.9.5 Starting the engine	24
5.9.6 Driving	24
5.9.7 Approaching and leaving the dock	25
5.9.8 Using the canopy	26
5.9.9 Doors and hatches	26
5.10 Proper use – other recommendations and guidelines	27
5.10.1 Man overboard	27
5.10.2 Securing loose equipment	27
5.10.3 Respect for the environment	27
5.10.4 Anchoring and mooring the boat	28
5.10.5 Towing	29
5.10.6 Trailer transport	29
5.10.7 Docking	31

6 Servicing and maintenance	32
6.1 Washing and waxing the boat	32
6.2 Care instructions for seat cushions	34
6.3 Care instructions for the canopy	34
6.4 Care instructions for the windscreen	34
6.5 Care instructions for the stainless steel components	35
6.6 Care instructions for the remote control	35
6.7 Care instructions for the steering system	35
6.8 Care instructions for electrical components	35
6.9 Minor surface repairs	36
7 Winter storage	37
7.1 Inspections before winter storage	37
7.2 Inspections before launching the boat	38
8 Lay-out	39
8.1 General lay-out	39
8.2 Fuel system	40
8.3 Steering system	41
8.4 Electrical system	41
Wiring diagram	42

BEFORE YOU SET OFF

Familiarise yourself with this owner's manual.

Always check at least the following items before leaving:

- **Weather conditions and forecast**
Take the wind, waves and visibility into account. Are the design category, size and equipment of your boat, as well as the skills of the skipper and crew, adequate for the waters you are headed for? Hull windows and hatches must be battened down during high wind and rough seas to prevent water incursion.
- **Loading and stability**
Do not overload the craft, and distribute loads appropriately. Heavy items are to be placed in the storage compartments under the aft bench. Also note that the boat is less stable if people stand up when on board.
- **Passengers**
Ensure that there are personal flotation devices or lifejackets for all people on board. Agree on crew tasks before setting off.
- **Fuel and fuel system**
Make sure that the boat has enough fuel, including a 20% reserve for heavy weather or other unforeseen eventualities.
- **Engine and manoeuvring equipment**
Check the function and condition of steering and remote control, and carry out routine checks according to the engine manual.
- **Seaworthiness of the boat**
Check the boat's seaworthiness: no fuel or water leaks, safety equipment available on board, etc. Check that there is no water in the bilge.
- **Equipment stowage**
Check that all onboard items are positioned so that they will stay in place even in rough seas and high winds. Please note that the seat cushions may fly overboard if they are not fixed properly with press studs.
- **Nautical charts**
Unless you are navigating in completely familiar waters, ensure you have nautical charts on board that cover a large enough area! If your boat is equipped with a chart plotter, learn to use it before setting off. Ensure that the plotter charts are of the latest edition.
- **Leaving the berth**
Agree with the crew who will release each mooring line, etc. Be careful not to let mooring lines or the anchoring line become fouled in the propeller during manoeuvring.
- **Obligatory equipment**
What is considered obligatory equipment varies between different countries. Find out what is required for your boat.

You will find additional instructions concerning the engine in the separate engine manual.

1 General

The user manual will help you familiarise yourself with the properties and features of your new boat and with its care and maintenance. Separate manuals for installed equipment are attached and are referred to in many sections of the user manual. You can supplement this user manual by adding the manuals of devices which are installed afterwards. There is also space for your own notes at the end of the manual.

The craft has a running serial number, a CIN code (Craft Identification Number). The CIN code can be found on the starboard side of the transom just below the bathing platform. We recommend that you write down the CIN code in the declaration of conformity in this book. When contacting the dealer, please provide the CIN code and the type of craft. This helps in delivering the correct spare parts.

Essential requirements	Standards	Other normative Document/ method	Technical file	Please specify in more details (*Mandatory Standards)
General requirements (2)	<input checked="" type="checkbox"/>			EN ISO 8666:2002 *
Craft Identification Number - CIN (2.1)	<input checked="" type="checkbox"/>			EN ISO 10087:2006 *
Builder's Plate (2.2)	<input type="checkbox"/>	<input checked="" type="checkbox"/>	<input type="checkbox"/>	RCD annex I, 2.2
Protection from falling overboard and means of reboarding (2.3)	<input checked="" type="checkbox"/>	<input type="checkbox"/>	<input type="checkbox"/>	EN ISO 15085:2003/DAM 2.3.2
Visibility from the main steering position (2.4)	<input checked="" type="checkbox"/>	<input type="checkbox"/>	<input type="checkbox"/>	EN ISO 11591:2011
Owner's manual (2.5)	<input checked="" type="checkbox"/>	<input type="checkbox"/>	<input type="checkbox"/>	EN ISO 10240:2004
Integrity and structural requirements (3)				
Structure (3.1)	<input checked="" type="checkbox"/>	<input type="checkbox"/>	<input type="checkbox"/>	EN ISO 12215-5:2008, EN ISO 12215-6:2008
Stability and freeboard (3.2)	<input checked="" type="checkbox"/>	<input type="checkbox"/>	<input type="checkbox"/>	EN ISO 12217-1:2015
Buoyancy and floatation (3.3)	<input checked="" type="checkbox"/>	<input type="checkbox"/>	<input type="checkbox"/>	EN ISO 12217-1:2015
Openings in hull, deck and superstructure (3.4)	<input checked="" type="checkbox"/>	<input type="checkbox"/>	<input type="checkbox"/>	EN ISO 9093-1:1997
Flooding (3.5)	<input checked="" type="checkbox"/>	<input type="checkbox"/>	<input type="checkbox"/>	EN ISO 15083:2003
Manufacturer's maximum recommended load (3.6)	<input checked="" type="checkbox"/>	<input type="checkbox"/>	<input type="checkbox"/>	EN ISO 14946:2001/AC 2005
Liferaft stowage (3.7)	<input type="checkbox"/>	<input checked="" type="checkbox"/>	<input type="checkbox"/>	RSG Guidelines
Escape (3.8)	<input type="checkbox"/>	<input type="checkbox"/>	<input type="checkbox"/>	
Anchoring, mooring and towing (3.9)	<input checked="" type="checkbox"/>	<input type="checkbox"/>	<input type="checkbox"/>	EN ISO 15084:2003
Handling characteristics (4)	<input checked="" type="checkbox"/>	<input type="checkbox"/>	<input type="checkbox"/>	EN ISO 11592:2001, EN ISO 8665:2006
Engines and engine spaces (5.1)				
Inboard engine (5.1.1)	<input type="checkbox"/>	<input type="checkbox"/>	<input type="checkbox"/>	
Ventilation (5.1.2)	<input type="checkbox"/>	<input type="checkbox"/>	<input type="checkbox"/>	
Exposed parts (5.1.3)	<input type="checkbox"/>	<input type="checkbox"/>	<input type="checkbox"/>	
Outboard engine starting (5.1.4)	<input type="checkbox"/>	<input type="checkbox"/>	<input type="checkbox"/>	
Fuel system (5.2)				
General – fuel system (5.2.1)	<input checked="" type="checkbox"/>	<input type="checkbox"/>	<input type="checkbox"/>	EN ISO 11105:1997
Fuel tanks (5.2.2)	<input checked="" type="checkbox"/>	<input type="checkbox"/>	<input type="checkbox"/>	EN ISO 10088:2013
Electrical systems (5.4)	<input checked="" type="checkbox"/>	<input type="checkbox"/>	<input type="checkbox"/>	EN ISO 10133:2012, EN ISO 8846:1993/A1:2000
Steering systems (5.4)				
General – steering system (5.4.1)	<input checked="" type="checkbox"/>	<input type="checkbox"/>	<input type="checkbox"/>	EN ISO 10592:1995/A1:2000
Emergency arrangements (5.4.2)	<input type="checkbox"/>	<input type="checkbox"/>	<input type="checkbox"/>	
Gas systems (5.5)	<input type="checkbox"/>	<input type="checkbox"/>	<input type="checkbox"/>	
Fire protection (5.6)				
General – fire protection(5.6.1)	<input checked="" type="checkbox"/>	<input type="checkbox"/>	<input type="checkbox"/>	EN ISO 9094:2015
Fire-fighting equipment (5.6.2)	<input checked="" type="checkbox"/>	<input type="checkbox"/>	<input type="checkbox"/>	EN ISO 9094-1:2015
Navigation lights (5.7)	<input type="checkbox"/>	<input checked="" type="checkbox"/>	<input type="checkbox"/>	1972 COLREG
Discharge prevention (5.8)	<input type="checkbox"/>	<input type="checkbox"/>	<input type="checkbox"/>	
Annex I.B – Exhaust Emissions	See the Declaration of Conformity of the engine manufacturer			
Annex I.C – Noise Emissions	<input type="checkbox"/>	<input type="checkbox"/>	<input type="checkbox"/>	
Noise emission levels (I.C.1)	<input type="checkbox"/>	<input type="checkbox"/>	<input type="checkbox"/>	
Owner's manual (I.C.2)	<input type="checkbox"/>	<input type="checkbox"/>	<input type="checkbox"/>	

2 Definitions

The warnings and cautions in this manual are defined as follows:

- DANGER!*** Denotes an extreme intrinsic hazard that will result in a high probability of death or permanent injury if proper precautions are not taken.
- WARNING!*** Denotes a hazard which can result in injury or death if proper precautions are not taken.
- NOTE!*** Denotes a reminder of safe practices or directs attention to unsafe practices which could result in personal injury or damage to the craft or components or the environment.

SI system units are used in this manual. In some cases, other units have been added in brackets. An exception is wind speed, for which the Beaufort scale is used in the Recreational Craft Directive.

3 Warranty

The boat and its factory-installed equipment have a two-year warranty, starting on the first day of use. Please contact your dealer regarding any potential warranty issues. Please remember to provide the CIN code. If possible, please provide a digital photograph of the subject of your claim. This usually speeds up the claims process.

4 Before use

4.1 Registration

Registration regulations vary between different countries. Find out what is required in relation to your own boat.

4.2 Insurance

Boat insurance can compensate damage occurring on water or during transport and lifting. Check who has insurance liability each time when having the boat lifted. Insurance also has an indirect effect on safety at sea: In the event of a serious accident or damage, you must, above all, concentrate on saving people. Insurance companies will be able to give more information about different insurance alternatives. Check who has insurance liability each time when having the boat lifted or transported!

4.3 Training

No one is a born sailor. There is plenty of boating literature available. Navigation courses are arranged by local yacht clubs or national boating associations where you can gain basic skills.

However, please remember that you only become confident in boat handling, navigation, docking and anchoring after long practical experience.

5 Characteristics and use of your boat

5.1 General

The user manual is not meant to be a complete service or repair manual; it simply guides the user to use his/her boat in a proper way.

Pictures and drawings of this manual might include optional or country-specific features.

5.2 Basic data

Recreational crafts can be constructed according to 4 categories (A, B, C and D) under the Recreational Craft Directive 2013/53/EU. This boat has been constructed according to design category C, which means the following:

The boat is built for conditions where the wind reaches a maximum of 6 Beaufort (c. 14 m/s) and for corresponding sea conditions (significant wave height no more than 2 m). Such conditions may be encountered on exposed inland waters, in estuaries, and in coastal waters in moderate weather conditions.

Significant wave height is the mean height of the highest third of the waves, which approximately corresponds to the wave height as estimated by an experienced observer. Individual waves may reach up to twice this height. If the significant wave height is 2.0 m, the mean height of all waves is roughly 1.2 m.

Maximum recommended load: See *technical specifications*
See also section 5.4 'Loading'.

Main dimensions and capacities: See *technical specifications*
Craft length, width, draught, total weight, etc., and tank capacities are shown in the technical specifications.

Builder's plate:
Part of the aforementioned information is given on the builder's plate, which is affixed next to the remote control. Supplementary information is provided in the appropriate sections of this manual.

Model	YAMARIN CROSS 64 Bow Rider
Design category	C
Overall length (swim ladder not included)	6.31 m
Width	2.32 m
Weight without engine, fluids and equipment	Approximately 880 kg
Weight on trailer with largest recommended engine	Approximately 1,163 kg Includes the boat (approx. 880 kg), a Yamaha F150 engine (218 kg) and the estimated weight of fluids and equipment (130 kg). NOTE! This is not the maximum weight of fluids and equipment.
Weight on trailer with the largest engine that complies with the standard	Approximately 1,206 kg Includes the boat (approx. 880 kg) and a 150 hp engine (261 kg) and the estimated weight of fluids and equipment (130 kg). NOTE! This is not the maximum weight of fluids and equipment.
Maximum weight of load / Maximum number of passengers	690 kg 8 persons (600 kg)
Maximum load includes	600 kg / 8 persons (75 kg each) + fuel 90 kg = 690 kg
Maximum load on builder's plate (CE sign)	600 kg Includes people 8 x 75 kg = 600 kg
Weight at full load	1,885 kg Includes boat 880 kg + engine 265 kg + battery 20 kg + fuel 90 kg + equipment 34 kg + persons 600 kg
Maximum engine power	111 kW / 150 HP
Weight of largest recommended engine	261 kg
Fuel tank capacity	126 litres
Maximum draught at full load, engine up	Approximately 0.4 m
Maximum height from water line at light load	Approximately 1.4 m
Construction material	Deck: Reinforced plastic Hull: 5083 Aluminium
Colour codes: - Deck	RAL 7046
Remote control cables	12 ft / 3.6 m x 2
Hydraulic hoses for steering system	5.5 m x 2
Maximum speed at performance test	c. 44 knots

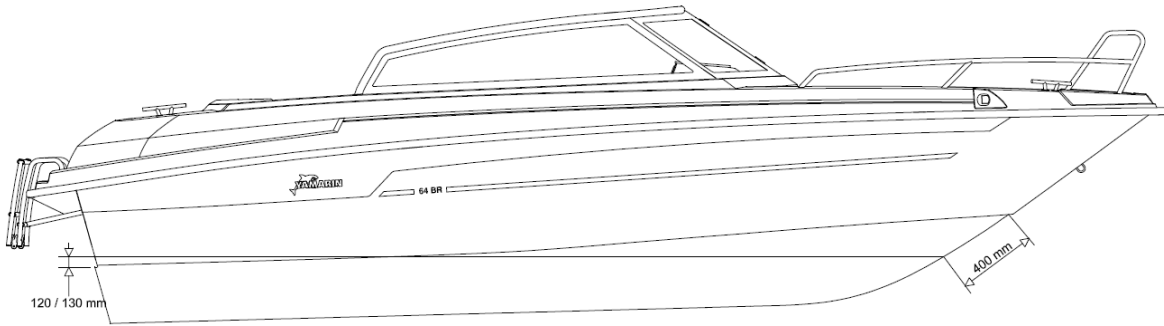

Image: Boat's water line.

Water line:	
- at stern	with a 115 HP engine 120mm up from chine 150 HP engine 130mm up from chine
- at bow	400 mm down from chine along the bow

NOTE! Water line dimensions represent the upper limit for antifoulingpaint, not the actual waterline.

5.3 Maximum recommended number of passengers:

The maximum recommended number of passengers on board this boat is 8 persons.

WARNING! Do not exceed the maximum recommended number of passengers. Regardless of the number of passengers, the total weight of people and equipment must never exceed the maximum recommended load (please refer to 'Loading'). All passengers must remain seated during travel.

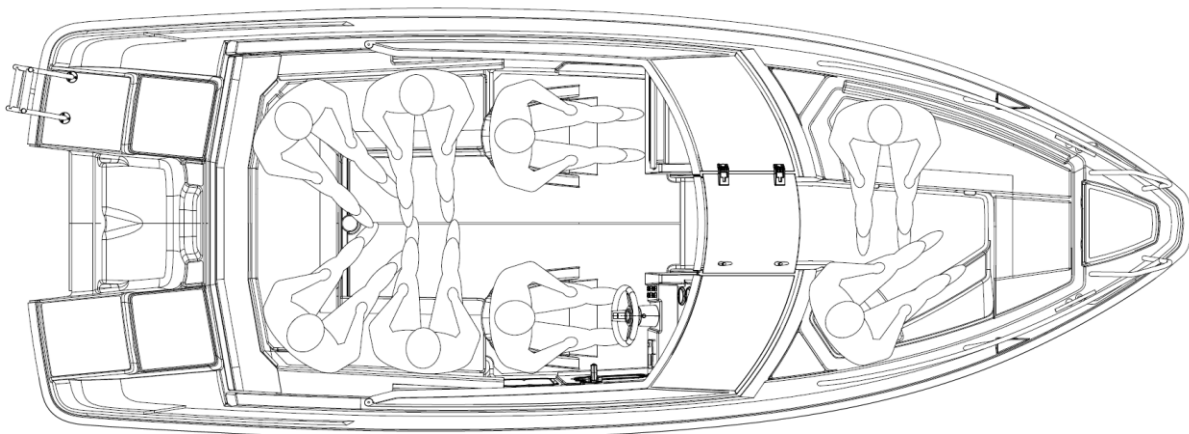

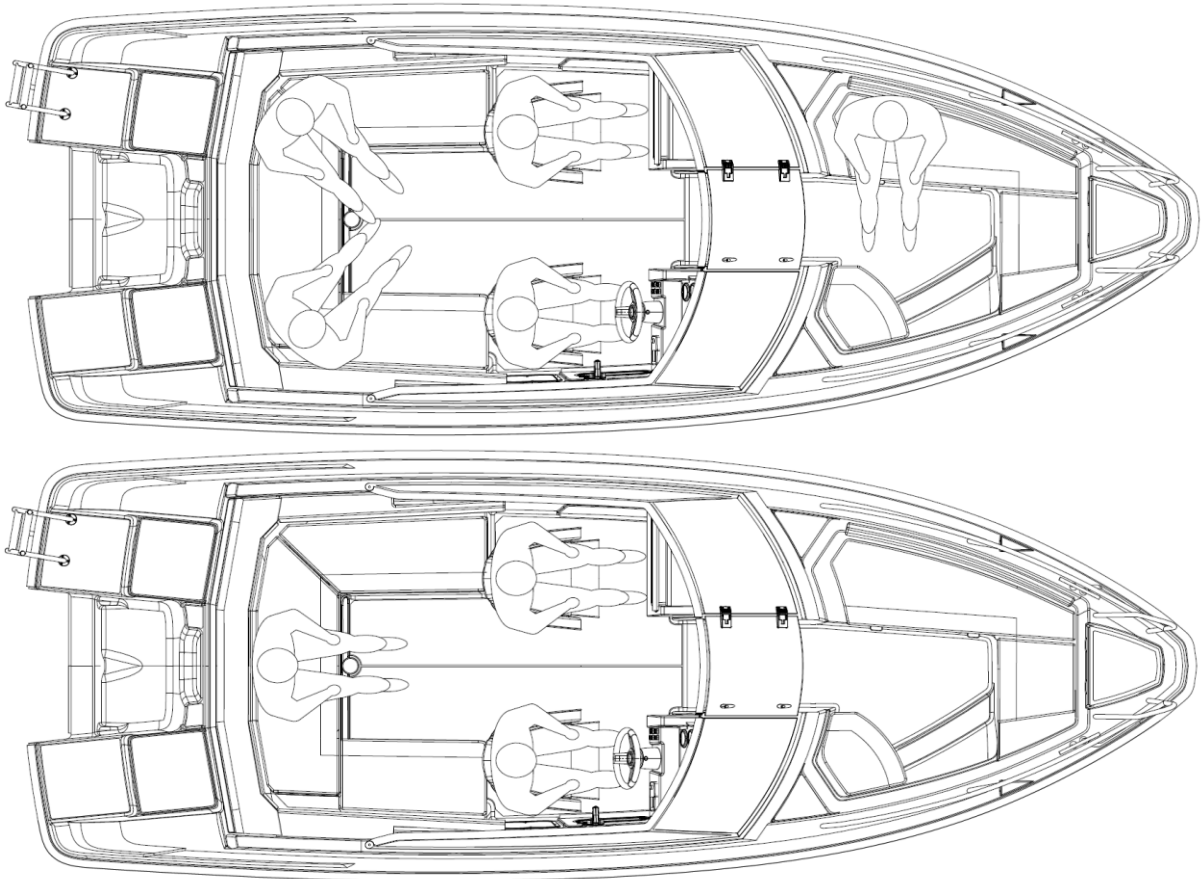

Image: Seats on the boat.

NOTE! If you load the boat from stern to bow, you will have better fuel economy.

5.4 Loading

The boat's maximum permitted load is 690 kg. This load includes the following weights:

- a) the total weight of passengers, 600 kg (the default weight of an adult is assumed to be 75 kg and that of a child 37.5 kg)
- b) and fluids (fuel) in fixed tanks, 90 kg

NOTE! The maximum permitted load only includes the weights mentioned above.

WARNING! **When loading the craft, never exceed the maximum recommended load.** Always load the craft carefully and distribute loads appropriately so that the boat is on an even keel. Heavy equipment should usually be placed in the storage compartment under the aft seat. Always avoid placing heavy items high up.

5.5 Engine and propeller

The maximum recommended engine power for the boat is 150 HP (111 kW). The construction of the boat is not designed to bear more power than 150 HP. Manoeuvring the boat can be very dangerous if the boat has an engine more powerful than 150 HP. The warranty is void if the boat is used with more power than 150 HP. Follow the dealer's instructions when choosing the propeller for your craft.

Yamaha F115	13 x 19" kss 688
Yamaha F150	13 ¾ x 21" Reliance M SDS

5.6 Prevention of water incursion and stability

5.6.1 Hull and deck through fittings and closing valves

The boat has a rainwater draining system, which means that rainwater is drained from the undecked part of the boat when the boat is on the water. The system also functions when the boat is out of water, provided that the bow is higher than the stern and closing valve is open.

The rainwater drainage closing valve is located under the middle hatch of the aft seat. This drain valve is meant to be shut only when at maximum load to prevent potential water incursion. **In other loading conditions, the drain valve should remain open to let rainwater drain from the boat.**

The boat is equipped with an electric bilge pump.

The switch of the bilge pump is dual-action:

- automatic action
- manual action

When the bilge pump is running, the switch is lit.

NOTE! Always keep the switch set to automatic action.

NOTE! If the light is lit, immediately check the boat's bilge and find out the reason for the leakage. Take immediate corrective action.

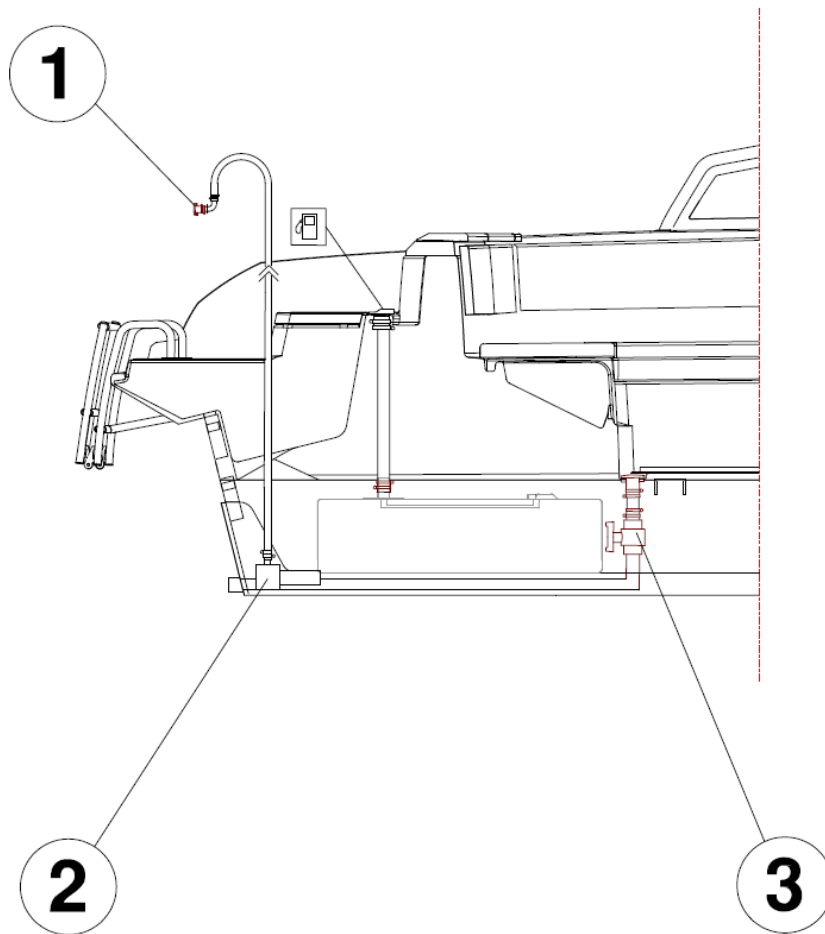

1. Bilge pump through fitting
2. Electric bilge pump
3. Open deck space shut-off valve (the rainwater drainage valves)

Image: Boat drainage system.

The owner of the boat is responsible for ensuring that there is at least one bailer or bucket on the boat and that it has been secured.

WARNING!

Always keep the drainpipe shut when its inboard end is constantly below the waterline due to loading. The shut-off flap on the transom only prevents water from entering the boat when reversing!

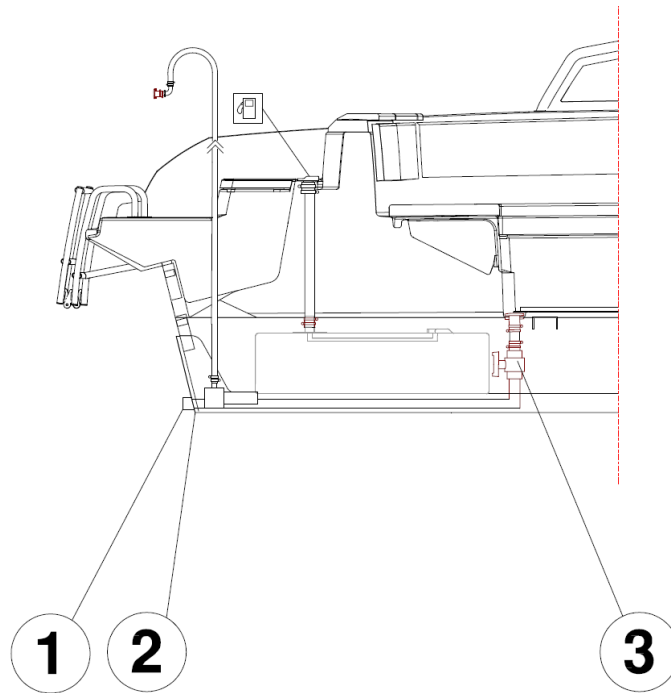

1. Shut-off flap
2. Drain plug
3. Open deck space shut-off valve (the rainwater drainage valves)

Image: Locations of through fittings and drainage valves.

NOTE!

Make sure that water can flow unobstructed through the drainpipe. Debris such as autumn leaves may obstruct the water flow, which can cause the boat to fill with water and sink. The bilge pump system does not work in conditions below 0°C.

NOTE!

There is always some condensed water in the bilge. The through fittings may also allow water to seep through, particularly as the boat ages. Always remember to check the bilge, via the inspection hatch under the aft seat, before you leave the boat at quay or buoy and always before setting off. Have any leaks repaired at an authorised repair shop.

WARNING!

The boat's handling properties may become extremely dangerous if there is water in the bilge.

WARNING!

In rough weather, hatches and drawers should be kept shut to prevent them filling with water.

5.6.2 Stability and buoyancy

Please note that stability is reduced by any weight added high up. Any change in the distribution of weight on board may significantly affect the stability, trim and performance of your craft. Please remember that large breaking waves always present a serious danger to stability.

The amount of water in the bilge must be kept as low as possible.

The boat's stability may be impaired during towing, or when passengers are lifting heavy items.

5.7 Preventing fires and explosion hazards

5.7.1 Refuelling

Shut off the engine and extinguish any cigarettes before starting to refuel. During refuelling, do not use switches or appliances that can cause a spark.

Always keep a spare can of fuel on board. The anchor boxes at the stern are especially suitable for storing the spare canister. There is no risk of vaporised fuel coming into contact with battery compartments or the electrical system from either of these boxes.

Do not stow any loose items under the aft seat that could prevent fuel flow to the engine if they shift. This is particularly important for items that may press against hoses or the fuel filter. Check the fuel hoses annually for wear, especially at through fittings.

Please note that depending on the trim of the boat or the boat's heeling angle, it might not be possible to use the full capacity of the fuel tank.

WARNING! Vaporised fuel is highly explosive. Observe strict caution and these instructions when refuelling. If you can smell fuel, that always means that there is vaporised fuel somewhere on your boat.

5.7.2 Fire protection

The boat is equipped with a portable 2 kg fire extinguisher of class 8A 68 B, which is the minimum requirement for extinguishers. The extinguisher is located in the storage compartment of the driver's console the boat must always have an approved and inspected extinguisher during use. The fire extinguisher must be inspected annually by an authorised inspector to ensure its functioning. In the event that the fire extinguisher is replaced, the capacity of the new one must be at least equivalent to the old.

NOTE! In a new boat the fire extinguisher might go out of date in a short period of time.

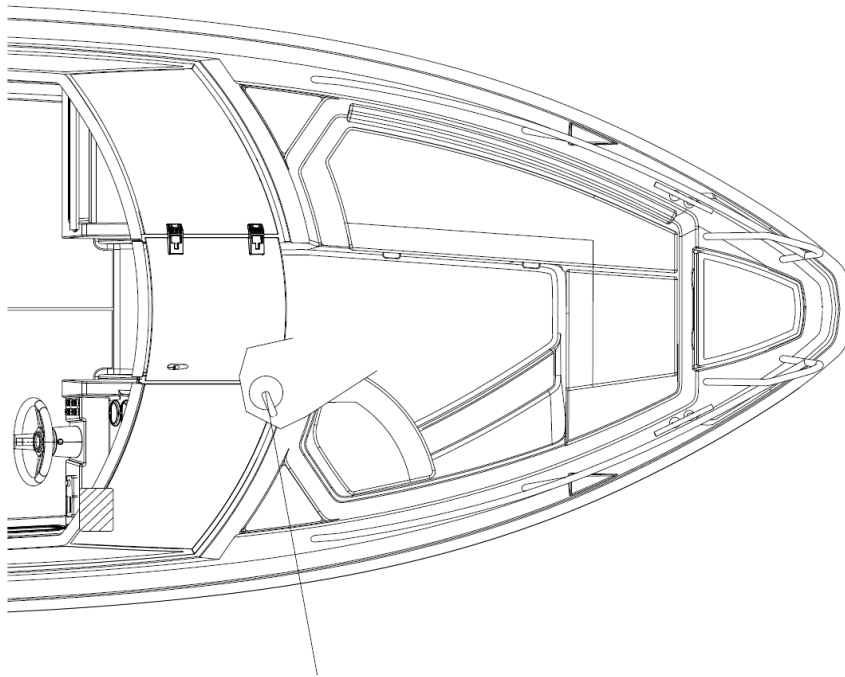

Image: Location of the fire extinguisher.

Ensure that fire-fighting equipment is readily accessible even when the boat is loaded.
Inform members of the crew about the location and operation of fire-fighting equipment.

Remember:

- Never hinder access to safety equipment, for instance the switches to the electric system.
- Never hinder access to fire extinguishers located in a box.
- Never make alterations to any of the boat's systems (especially the electricity or the fuel systems) or allow an unqualified person to make alterations to any of the boat's systems.
- Never smoke while handling petrol or gas.

NOTE!

Always keep the bilge clean and regularly check for any fuel leaks.

5.8 Main power switch and fuses

Electric circuit fuses are located on the panel of the main power switch. Do not change the circuit breaker amperages or install any components that exceed the nominal amperage of the circuit in the electric system.

Operation of the main power switch:

- turn handle clockwise -> circuit engaged
- turn handle counter-clockwise -> battery disengaged from circuit



Image: Main power switch and circuit breakers.

F1 = Running lights
F2 = Bilge pump
F3 = Plotter/Radio
F4 = Trims

F5 = 12V outlet
F6 = Wiper
F7 = Memory

All fuses on the boat are automatic circuit breakers. In the event of a fault current, the circuit breaker will trip. You can reset the circuit breaker by pushing it back in. If the circuit breaker immediately trips again, there is a short-circuit somewhere in the electrical system or in a component. You must leave repairing the boat's electrical system to a professional electrician.

NOTE! Never cut the power from the main power switch while the engine is running, as this may cause damage to the engine's electrical system.

NOTE! Never install electric equipment on the boat with the power switched on.

NOTE! When installing accessories, it is important to use circuits and circuit breakers intended for them. Connect the device to both the live wire and the ground wire. **Never use the hull of the boat as ground.**

NOTE! When connecting or disconnecting the battery, do not touch both terminals, or a terminal and the hull of the boat simultaneously with metal objects.

5.9 Operation

If this is your first boat or a boat type new to you, take someone with experience of a similar boat with you the first few times you operate it.

NOTE! The boat's maximum propulsion power is 111 kW (150 HP). Do not use the boat if its engine has a higher power rating than the one given on the builder's plate.

5.9.1 Controls

You will quickly learn how to control your boat, but changing weather conditions, such as wind and waves, will always present new challenges for the driver. The remote control combines the functions of throttle, forward and reverse gears, and the adjusting of the engine trim angle.

5.9.2 Emergency switch

The emergency switch is a device with one end attached to the switch under the remote control and the other end for instance to your lifejacket. The emergency switch automatically switches off the engine when detached from the remote control. It is very important that the boat will come to a halt in the event that the driver, for whatever reason, loses his/her balance and is flung from the helm.

NOTE! Never take control of the boat without having attached the emergency switch to yourself. If you attach it to your arm, do not steer the boat with that arm, because the emergency switch line may get caught on the wheel in sharp turns.

NOTE! The engine will not start if the emergency switch is not attached to the switch on the remote control.

DANGER! A rotating propeller presents a life-threatening danger to a swimmer or a person who has fallen overboard. Always use the emergency switch to turn off the engine when a swimmer or water skier is about to re-enter the boat from the water.

5.9.3 Gearshift and throttle

The engine is put into gear by pushing the button on the gear/throttle handle upwards with your fingers and by pushing or pulling the gear/throttle lever forward or backward, depending on the direction in which you are planning to go. When the engine is in gear, you can adjust the boat's speed using the same gear/throttle lever.

When the boat is travelling forward slowly, you can use the reverse gear for braking when approaching the dock, for instance. You must not shift into reverse if the boat is travelling at higher speeds, because it will damage the engine.

5.9.4 Adjusting of trim angle

These are the main rules when adjusting the trim angle:

- When bringing the boat to plane, keep the 'bow down' position
- When the boat is planing and seas are calm, keep lifting the bow until you can feel that both the engine and the boat move very easily. In calm waters, the engine should normally be trimmed up at least 3 scale marks on the trim indicator on the revolution counter. If the engine is trimmed up too much, the speed of the boat will be reduced. If the boat is trimmed too low, the boat will run slowly and the engine will run heavily. To achieve good fuel economy, it is important to drive the boat with the right engine trim angle.
- In heavy head seas, lower the bow to allow it to slice through the waves better, thus providing a smoother ride.
- In following seas, raise the bow to avoid 'diving' into the waves.
- When reversing, raise the trim angle slightly to bring the engine up.

WARNING! Do not drive the boat at high speeds with the engine trimmed up (bow up), as there is a risk of sudden heeling when the propeller hits the water again after a flight in heavy waves. Likewise, do not drive at high speed with the engine completely trimmed down (bow down) since this can cause the boat to pitch unexpectedly when the bow hits the water.

WARNING! Waves reduce manoeuvrability and make the boat heel. Accordingly, reduce speed when encountering heavier seas.

5.9.5 Starting the engine

1. Switch the power on using the main power switch.
2. Lower the engine to the driving position by pressing the Power Trim button on the gear/throttle handle.
3. Check that the gear/throttle handle is in the neutral position and that the emergency switch is attached to the bottom of the remote control.
4. Switch on the current, using the start key, without starting the engine and wait a few seconds for the warning lights to light up.
5. Start the engine by turning the ignition key clockwise until the engine starts. If everything is in order, the engine should start within 1-2 seconds. If the engine does not start, you should not try to start it for more than 10 seconds at a time.
6. After the engine has started, let it idle for a few minutes before setting off. (Please refer to the engine manual!)

For more detailed information, please refer to the engine manual.

5.9.6 Driving

It is easy to drive when the weather is fine and the sea is calm. However, always remember to keep an adequate lookout. In order to maintain the best possible visibility from the driver's position, you should do this:

- Ensure that passengers do not restrict your visibility.
- Do not drive near planing speed for long periods, as the bow up comes up and reduces visibility.
- When visibility is poor, look over the windscreen.
- Remember to also keep a lookout behind you, particularly on shipping lanes and heavily trafficked routes.

NOTE! Use navigation lights in darkness.

Always adjust your speed to prevailing conditions and the environment. Take into account the following:

- waves (also consult the passengers on what is a comfortable speed);
- your own bow wake (greatest at planing speed, smallest at speeds under 5 knots);
- maintaining adequate lookout;
- visibility (islands, fog, rain, driving against the sun);
- familiarity with the route (time required for navigation);
- rules of priority (other traffic); and
- width of the route (other traffic, noise and bow wake near shore).
- Make sure to always maintain a sufficient distance to avoid collision. The distance must be sufficient to stop the boat or to take evasive action.

When running at low speed, a planing boat's directional stability is poorer than at higher speeds. So be careful in narrow passages and, particularly, when meeting other boats.

You must learn the rules of traffic on sea lanes and follow the international regulations on how to avoid collisions at sea, COLREG. Navigate with care and use new or updated nautical charts.

The running position of the boat greatly affects its handling characteristics and fuel consumption and visibility from the driver's position. You can affect the running position by:

- placing the load properly – the general rule being that you should place as little weight in the bow as possible; and
- adjusting the trim angle.

The combination of the right running position with the right speed also makes driving in rough seas safer and more comfortable.

WARNING! A high speed and sudden manoeuvring can lead to large heeling angles and loss of control over the boat.

WARNING! This boat was not designed for use in temperatures under 0° C. In sub-zero temperatures, the drainage system freezes up and does not work as it should.

NOTE! The boat is not designed to jump waves. The warranty does not cover damage caused by jumping waves with the boat. You can check whether the boat has been airborne by reviewing the engine history on the computer at the maintenance shop.

5.9.7 Approaching and leaving the dock

Practise boat manoeuvring skills where there is ample space to learn how to approach a dock before entering a crowded marina.

A very gentle application of throttle does not generate sufficient steering power. Sharp but short throttle applications enable efficient steering movements when approaching the dock.

Ensure that everyone on board who does not have to stand up is seated when you are approaching the dock. Sudden steering movements may cause the boat to heel and injure somebody.

Before docking, prepare the mooring lines at stern and bow. Approach the dock bow first at an acute angle. Just before touching the dock, steer into it and shift into reverse. Apply throttle quickly and sharply. The boat will stop and turn parallel to the dock. If possible, make the approach into the wind or current, whichever is the strongest. This makes departing easier, as the wind or current will push the bow out from the dock. The easiest way to depart is to first push the stern as far away from the dock as possible, and then slowly reverse away from the dock into open water.

The propeller is designed to have the best grip in forward gear. Therefore, propeller performance is weaker in reverse. The steering response is also not as good in reverse as in forward gear.

WARNING! The boat is fast. If you are planing, it takes time to come to a stop. Slow down in time before anchoring, beaching or docking. Learn to estimate the distance the boat needs to stop. Remember that steering control is poor if there is no traction.

WARNING! Do not try to stop the boat with your hands, and do not put your arm or foot between the boat and the dock, the shore or another vessel! Practise beaching and docking under favourable conditions! Use moderate but firm engine power!

NOTE! When securing your boat, take into consideration the possibility of changes in wind direction, rising or sinking of the water level, bow wakes, etc. You can get more information from your insurance company, for example.

5.9.8 Using the canopy

The canopy is designed to withstand a maximum speed of 30 knots at sea, and 50 km/h in road transport. All press studs must be properly fastened when using the canopy. We recommend that you remove the sides and back of the canopy to make it fit into the canopy box more easily. Then, fold the upper parts of the sides entirely on top of the roof, so that no fabric remains where the corners of the canopy supports are. Finally, roll up the roof part along with the sides folded on top of it, and lower the canopy into the canopy box.

NOTE! The windscreen and canopy do not necessarily form a watertight seal. Water may enter the boat between the canopy and windscreen when the canopy is up.

5.9.9 Doors and hatches

Doors must always be kept shut and locked while driving.

WARNING! Large waves or gusts of wind may slam the door shut also when the boat is stationary. It is thus recommended to always keep the door closed when passage through the bow deck is not being used.

The bow anchor box hatch is equipped with a rubber band that holds the hatch closed while driving.

WARNING! It is recommended that children do not use the hatch, as their fingers or toes could get caught in it.

5.10 Proper use – other recommendations and guidelines

5.10.1 Man overboard

It is always a serious situation when someone falls overboard. Rescue procedures should be practised in advance during good weather, because it is too late for practice when someone has actually fallen into the water.

The boat is equipped with the fixed swim ladder that can be lowered down from the water.

It is always easiest to help a person climb back on board at the stern of the boat. A rope loop attached to the boat helps lifting. The boat's swim ladder extends 30 cm into the water.

It is very important to maintain visual and verbal contact with a person that has fallen overboard.

DANGER!

A rotating propeller presents a life-threatening danger to a swimmer or a person who has fallen overboard. Always use the emergency switch to turn off the engine when a swimmer or water skier is about to enter the water or re-enter the boat from the water.

5.10.2 Securing loose equipment

Stow all heavy equipment, such as anchors, and secure them firmly before setting off.

5.10.3 Respect for the environment

Conservation of the environment is a matter of honour for every boater. Therefore, you should avoid:

- fuel and oil leaks;
- emptying rubbish and waste into the water or on the shore;
- letting detergents or solvents get into the water;
- loud noise both on the water and at the marina; and
- producing an unnecessarily high bow wake, especially in narrow passages and shallow waters.

Service the engine well and run it at the most economical speed, which will also keep exhaust emissions low.

Please also consider other local environmental legislation and regulations. In Finland, under 'everyman's rights' anyone may move around on private land, except in the vicinity of residential buildings, as long as they cause no damage or inconvenience. 'Everyman's rights' also allow movement and temporary anchorages on privately owned waters, swimming and going on shore at uninhabited locations, unless landing is specifically prohibited by a notice from the authorities. It is not allowed to anchor next to a shoreline where there are one or more residences. Docking at a private dock owned by someone else or landing on a shore where there are residences is also not allowed without permission.

Please make sure to familiarise yourself with the International Convention for the Prevention of Pollution From Ships (MARPOL) and respect it to the greatest possible extent.

It is allowed to camp out on islands as long as no damage is caused to the landowner. It is not allowed to camp out next to residential buildings or in or near cultivated fields. You may not light a campfire unless you have the landowner's permission. Everyman's rights allow the picking of naturally growing berries and mushrooms without damaging trees or the environment in general. Please check the regulations concerning movement in the natural environment are in your area.

5.10.4 Anchoring and mooring the boat

Always moor your boat carefully, even in sheltered places, because conditions can change rapidly. Mooring lines should be equipped with absorbers to dampen any jolts. Please refer to the section on *Towing* for the location of bollards. To prevent abrasion, use fenders that are large enough.

The loop at the bow of the boat is for locking the boat to trailer. The loop on the deck is for locking the boat (to a dock, for instance). The locations of the loops are shown in section 8.

NOTE! Make sure that the lock or chain does not scratch the deck of the boat.

The forward endurance of the bow bollards is about 20.9 kN, or c. 2000 kg.
The backward endurance of the stern bollards is at least 14.6 kN, or c. 1400 kg.
The ultimate strength of mooring lines should be smaller than that of the bollard they are attached to. This means that the line will snap before the bollard or its mount fails.

The minimum anchor weight for the boat is 5 kg. Drop anchor far enough from shore. A reasonable grip is attained if the anchor line length is 4–5 times the water depth.

WARNING! Do not try to stop the boat with your hands, and do not put your arm or foot between the boat and the dock, the shore or another vessel!

NOTE! When securing your boat, take into consideration the possibility of changes in wind direction, rising or sinking of the water level, bow wakes, etc. You can get more information from your insurance company, for example.

NOTE! It is the owner's / user's responsibility to make sure that the boat's mooring and anchoring equipment is suitable for the boat's intended use.

5.10.5 Towing

When towing another boat, use a floating line that is strong enough for the task. Begin towing slowly, avoid jerks, and do not overload the engine.

The owner of the boat should consider the measures necessary for securing the boat's towrope.

If you are towing, or if your boat has to be towed, attach the towline to the bollards as per the following image.

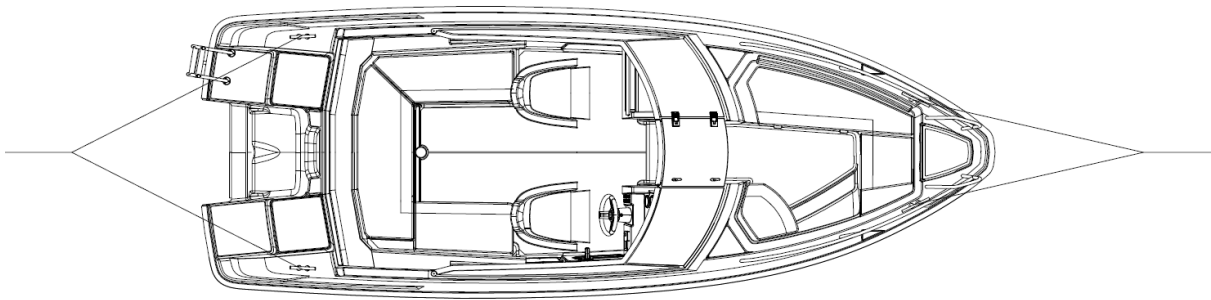

Image: Attaching the towline to the bollards.

WARNING! When towing, the towline is under high tension. If it should break, the end that snaps off may lash back fast enough to cause serious injury or death. Always use a thick enough line and keep to one side of the towline.

NOTE! When towing another boat or being towed, always drive at low speed. If the boat has a displacement hull, never exceed hull speed while towing. (The speed before the boat rises to plane).

NOTE! The towline should always be fastened so that it can be unfastened under load.

5.10.6 Trailer transport

Weight data for trailer transport may be found in the *technical specifications*. The trailer's keel supports should carry most of the weight of the boat. Adjust the keel supports so that the boat cannot slide from side to side. Adjust the side supports so that the boat will not rock sideways. For more information, please consult your dealer.

Clean the supports of sand and dirt so that they will not scratch the bottom of the boat. Double-check that the trailer is securely coupled to the trailer tow hitch!

The place for lifting the boat out of the water should be sheltered, and the ramp should extend deep enough into the water. Reverse the trailer so deep into the water that the rearmost keel support is just above the water. Drive the boat carefully towards the rearmost keel support and fasten the winch cable to the trailer hook.

Reel the boat up onto the trailer, taking care that the boat remains straight on the trailer's centre line. Remember to trim up the engine before reeling the boat onto the trailer so that it will not hit the bottom.

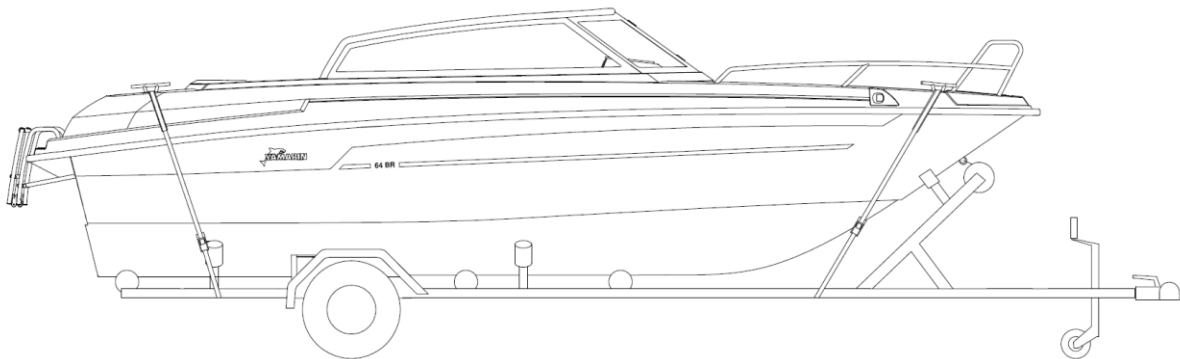

Image: Attaching the boat to the trailer.

Tie the boat properly before beginning transport. The sling ropes at the bow should be directed down and back, and the sling ropes at stern should be directed down and front. Do not leave any loose equipment or extra load on the boat when it is being transported. Remove the seat cushions and close all hatches properly.

The engine should be in the driving position during transport. However, ensure that there remains adequate clearance. Lift the engine to provide some clearance but not all the way up. For detailed instructions, see the engine's manual.

Wash and rinse the boat immediately after transport. Take special care when washing an aluminium hull if the roads have been salted. Road salt can leave permanent marks on an aluminium hull if it is not washed off. If the boat is kept on the trailer between transports, you must loosen the sling ropes for the duration and tighten them before the next transport.

NOTE!

The trailer should be slightly front-weighted. Appropriate nose weight is 4 % of the total mass of the trailer, but not less than 25 kg. Nose weight must not exceed the maximum vertical load on tow ball. Maximum load is defined by manufacturer of the towing vehicle. Make sure that the boat is fastened tight enough to the trailer and that the weight of the boat is divided equally between side supports. If the boat swings against a side support during transport, it may sustain hull damage.

NOTE!

If your boat is equipped with a Water skiing bracket (an accessory), please ensure that the engine will not tilt, with the engine casing hitting the bracket, during transport.

When letting the boat down from the trailer, remember to fasten the bow rope to the boat beforehand so that you can release the cable from the trailer hook as soon as the boat is in the water. Be careful with the winch handle!

5.10.7 Docking

The storage cradle should be sufficiently steady and suitable for this particular boat and engine combination. A sturdy plank (e.g. a 2x4) should be placed between the V trestles to support the keel and the bear most of the weight of the boat. The boat must not rest on the side supports. The side supports should not be placed touching the bottom chine, and point loads should be avoided. The supporting structures should be strong, particularly near the transom, to support the added weight of the engine. Storage cradle dimensions are shown in the picture below.

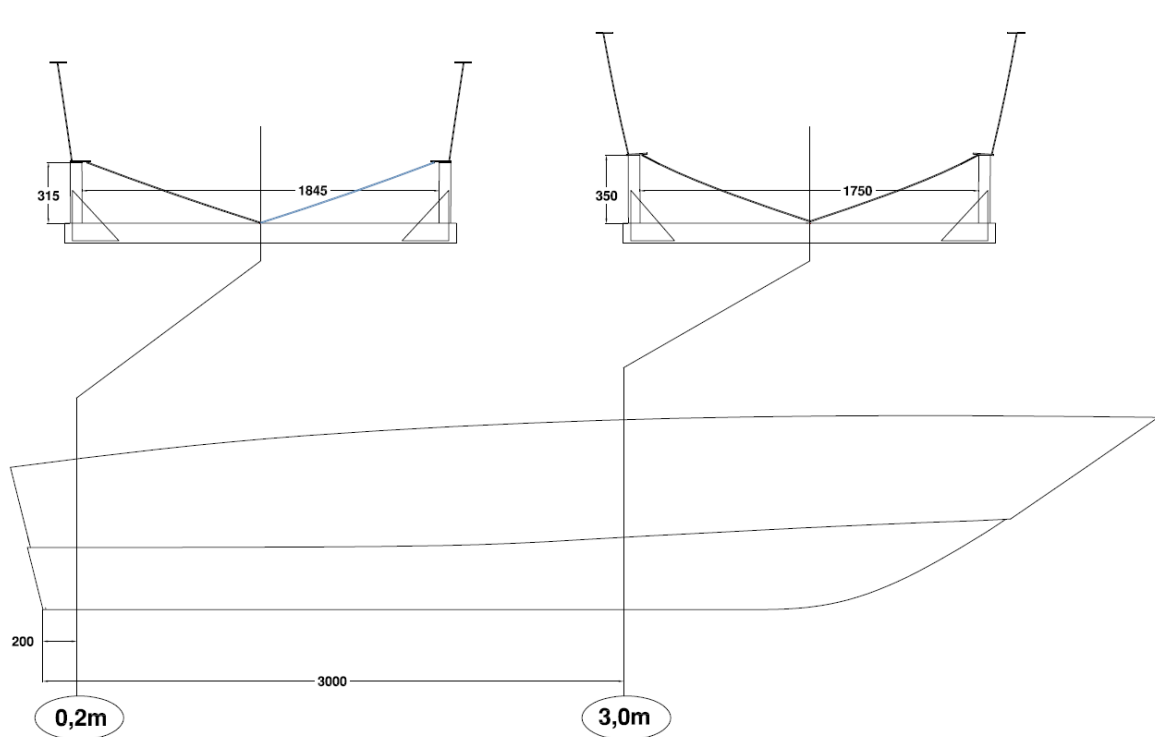

Image: Storage cradle dimensions.

Only use reputable lifting companies or boat yards with sufficient lifting capacity. In addition to the boat's tare weight (please refer to the technical specification), also take into consideration accessories and other possible loads in the boat.

When the boat is being lifted, the lines must be placed under the boat and the boat must remain horizontal during lifting.

NOTE! Do not lift the boat by its bollards.

DANGER! Never stand under a boat that is suspended from a crane.

6 Servicing and maintenance

Keep your boat and its equipment clean and tidy. This increases comfort and safety on board, and also the boat's resale value.

Familiarise yourself with the service procedures shown in the engine manual (see annex). Have your engine serviced according to the instructions in the manual.

6.1 Washing and waxing the boat

Cleaning fibreglass surfaces

Normally it is sufficient to just wash and wax the deck. Special boat cleaning agents are most suitable for the purpose. Do not use strong solvents; they can cause glossy surfaces to fade. Mildly abrasive polishes can be used to remove chafes and embedded dirt from the deck. The boat's aluminium and fibre glass surfaces can be washed with a pressure washer. Observe the chemical manufacturer's instructions when washing and cleaning the deck. The cleaning and maintenance instructions given here apply to Star brite products, available at well-stocked boating shops.

Useful tip: Washing the boat will be easier if it is done immediately after getting the boat out of the water.

NOTE! Do not spray water with a pressure washer on the caulking seam under the fender list. Pressurised water can damage the glued seam.

NOTE! Do not spray water directly into the air intake grilles. The water could get into the boat and into the structures.

The hatches of the glove compartment and instrument panel are made of plastic and can be washed with soap water; never use solvents to clean them.

Cleaning the aluminium hull

First wash off loose dirt above the water line using *Star brite Boat Wash in a Bottle* (a concentrated boat washing chemical, to be used in a mixture of 3 corkfuls per 10 l of water). Remember to dry the boat.

The waterline and bottom of the boat must be washed in temperatures of at least +10 °C, and only after the hull is completely dry. For the waterline and the bottom, use *Star brite Aluminium Cleaner*, which cleans the waterline and bottom of slime and grime.

Star brite Aluminium Cleaner is easy to use: Pour some cleaner in a plastic bucket and brush the hull of the boat with vertical strokes from the bottom up to prevent trickling. Let the cleaner take effect for 1–2 minutes (but do not let it dry). Rinse thoroughly. The cleaning process can be enhanced and speeded up by rubbing the surface with a sponge or a brush while the cleaner is applied. If you are working in the sunshine, only apply cleaner to an area that you will have time to wash before it dries.

Protecting the aluminium hull

When the aluminium hull is completely clean and dry, it can be protected against oxidation. *Spray Star brite Aluminium Polish* on the surface to be treated and spread it out with a soft, lint-free cloth. We recommend that you treat your new boat with *Star brite Aluminium Protectant* before launching it to prevent oxidation of the aluminium surfaces. Oxidation is a natural reaction of aluminium against corrosion and only affects the appearance of the boat, not its quality otherwise.

Useful tip: If you wash your boat with tap water, it will leave behind a thin, chalk-like deposit of calcium and other minerals due to the water hardness. This can be prevented by mixing a few drops of pine soap solution into a bucketful of rinsing water.

Useful tip: Water and lime stains on stainless steel rails can be removed using *Lemon Pled* furniture spray.

Useful tip: If the boat ropes smell bad after winter storage, immerse them for a couple of hours in a bucket of water with a bottle of apple wine vinegar and a splash of fabric conditioner mixed in. Let dry properly, and the ropes will be as good as new.

NOTE! Make sure that the cleaning, polishing and protective agents you use are suitable for aluminium and the other surfaces you will treat with them. Always follow the chemical manufacturer's instructions.

Aluminium tread plates

Tread plates are in black anodised aluminium.
Black anodised aluminium will fade slightly in the sunlight.
The warranty does not cover faded floor plates, as fading is a feature, not a manufacturing defect.

NOTE! On hot summer days, black aluminium floor plates may become hot. It is worth reminding those on board about this, barefoot small children in particular.

6.2 Care instructions for seat cushions

Always use the canopy or harbour cover when it is raining to protect the seat cushions. Although the seat cushions are made of water-resistant material, water can get in through their seams. If the cushions remain damp for any length of time, they may get mouldy and be ruined. If the mattresses get wet, the fabric can be removed by unzipping the mattress and dried in the sun, at room temperature or in a sauna (max +50°C). The warranty does not cover cushions spoiled by rain or damp.

NOTE! To keep the seat cushions in good condition over the winter, they must be stored in a dry and well-ventilated place.

NOTE! Wet cushions should not be placed in storage, because they gather mould easily.

NOTE! Single seats must be covered with seat covers when boat is not in use. If seats have got wet during the use of the boat, they must be dried carefully before covering.

The press studs of the seat cushions should be sprayed with silicon spray every now and then, otherwise they may become so tight that the fabric will tear when trying to open them. The warranty does not cover ripped seat cushions. Use very little silicon spray at a time in order not to stain the cushions.

6.3 Care instructions for the canopy

Store the canopy over winter in a dry and well-ventilated place. The warranty does not cover a torn canopy.

6.4 Care instructions for the windscreen

The boat's windscreen is made of tempered glass and can be cleaned with ordinary glass cleaners.

The middle door between the consoles on the boat (lower half) is made of acrylic and can be washed with soap and water (e.g. car shampoo). Do not use solvents on acrylic.

Useful tip: When wiping the boat's windscreen dry after cleaning, avoid using circular motions. This can leave circular smudges on the windscreen that become visible in sunlight, impeding visibility. Use newspaper or a cotton rag, using first horizontal, then vertical motions. Repeat this a few times and you'll bring the windscreen to a brilliant shine.

6.5 Care instructions for the stainless steel components

To keep the boat's stainless steel parts, such as rails, handles and bollards, shining as good as new, you should keep the parts clean and waxed. The edges of the mounting flanges of the rails should also be cleaned. Any dirt that remains under the edge of the flange will begin to look like rust. In regular use (i.e. no damage), the parts should be cleaned and waxed at least twice every summer. The rails should also be cleaned and waxed in autumn, when the boat is put into winter storage.

6.6 Care instructions for the remote control

Normally, the remote control needs no other maintenance apart from greasing and calibration during winter servicing. If the remote control becomes stiff for any reason, it needs to be serviced immediately.

6.7 Care instructions for the steering system

The hydraulic steering does not require maintenance under normal circumstances. If the steering starts to feel loose, there is a leak somewhere in the system. Leaks must be repaired immediately!

WARNING!

A hydraulic steering system that has a leak or trapped air in the hoses is extremely dangerous.

6.8 Care instructions for electrical components

Electrical components such as the main power switch, other switches and connectors do not normally need to be serviced if the boat is stored in a dry and well-ventilated place for the winter. If, however, you wish to protect electrical components against oxidation, the best way to do it is by spraying them every now and then with a moisture repellent antioxidant.

6.9 Minor surface repairs

You can repair minor surface damage to the boat's deck yourself. However, achieving a neat, unnoticeable repair requires a considerable amount of skill:

1. Protect the area around the damage with tape.
2. Bevel the edges of the damaged area and clean with acetone.
3. If the damage is deeper than 2 mm, it is advisable to smooth it with an appropriate polyfiller before painting.
4. Mix topcoat with 1.5-2% hardener.
5. Fill the repair with more topcoat than needed, so that its surface remains slightly proud of the surrounding area.
6. Carefully put tape over the repair.
7. After the topcoat has hardened, remove the tape and sand the repair using 600 and 1200 paper applying water.
8. buff using abrasive paste and wax

The colours used on this boat are specified in the *Technical specifications*. One point to consider is that a paint called gelcoat has been used in manufacturing the boat, but the surface is always repaired with a paint called topcoat. Gelcoat paint does not harden without a mould surface, whereas paraffin has been added to topcoat to allow it to harden.

WARNING!

Be careful when handling the hardening agent. If the hardening agent vessel / bottle leaks, or some agent drops onto a dirty floor or rag, there is a very high risk of the surface catching fire. Do not throw into the rubbish bin any rags or vessels containing topcoat / hardening agent mixture. Always use protective eyewear when handling topcoat or hardening agent. If you get hardening agent in your eyes, immediately rinse with tap water and then consult a doctor.

NOTE!

Later installations and alterations, if incorrectly carried out, may damage the structure of the boat or compromise safety. Please contact the dealer if you are planning any modifications.

NOTE!

It is important to use aluminium or stainless steel screws and rivets when installing accessories. There are ready-made fittings for a depth finder sensor (Garmin) on the boat's transom.

NOTE!

When installing accessories on an aluminium surface (**except in predetermined locations**), always use aluminium rivets and insulating washers to avoid corrosion.

7 Winter storage

Preparing your boat for winter storage is an annual routine. Have your boat lifted in good time before the water freezes. Your boat is not designed for use in ice and it is not meant to be used in temperatures below zero (for example, the rain water drainage system will freeze up). It is advisable to perform all maintenance, repair and inspection procedures in connection with placing the boat in winter storage.

Familiarise yourself with the service procedures shown in the engine manual. We recommend that you leave them to an authorised service agent. Do not forget to service the remote control and steering system. Make sure to perform their maintenance according to their separate instructions and manuals.

7.1 Inspections before winter storage

Have your boat lifted in good time before the water freezes. Your boat is not designed for being driven in ice, or for remaining in the water when it freezes.

Wash the bottom of the boat immediately after the boat has been lifted. Algae and slime will come off easier if they are not left to dry.

Give the engine and other equipment their winter servicing, following their separate manuals. If your boat is stored outside or in a humid place over the winter, empty it of textiles and other equipment that may corrode or become mouldy in damp conditions. Wash the ropes in fresh water. Replace any worn ropes. Leave bushing valves open. Remove the drain plug for the winter.

Electronic instruments are best protected against oxidation and theft by detaching them and removing them to a dry indoor environment for the winter. Detach the batteries and store them in a warm, dry place. Charge the batteries at least twice during the winter. Spray the couplings of the electrical system with an appropriate water repellent antioxidant.

Always cover your boat so that water or snow cannot gather inside. Always make sure, however, that it is adequately ventilated. A winter storage cover is available as an optional accessory for your boat.

NOTE! Make sure that the winter storage cover or its ropes do not touch the aluminium hull. If the cover or its ropes abrade the hull, they will leave black marks on it.

NOTE! Make sure the rain water drainage pipe is clean of dirt. This can be done e.g. by flushing it with a water hose.

7.2 Inspections before launching the boat

Repair any damage to the gelcoat surface according to section 6.9.

In sea areas, antifouling paint should be used to prevent the hull from becoming covered with vegetation. Fouling of the bottom and especially the propeller increases fuel consumption remarkably. However, if the boat is anchored at the inlet of a stream or in a land-locked lake, or if it is lifted out of the water at least once every two weeks, it is normally not necessary to use antifouling paint. Carefully follow the paint manufacturer's instructions when applying the paint. When sanding old antifouling paint, remember that the dust is toxic. Antifouling paint is not necessary in fresh water (lake areas).

NOTE! Do not apply any paint to the zinc anodes, depth finder sensor, or piston rods of the hydraulic trim tabs. Do not apply paints containing copper or lead on aluminium parts. And remember to follow the paint manufacturer's instructions. The warranty does not cover damage caused to the hull by antifouling paint containing lead or copper.

NOTE! Make sure the rain water drainage pipe is clean of dirt. This can be done e.g. by flushing it with a water hose.

Useful tip: Do not throw away a used paint brush. A dried-up antifouling paintbrush can be rejuvenated by soaking it for a couple of hours in a mixture of 2 l hot water, 1 dl vinegar and 0.5 dl baking powder.

Perform the necessary service procedures required for the engine according to the engine manual. Check the functioning of electric equipment and remove any oxidation from fuse connectors etc.

Remember that petrol goes stale over time, and you must always start the engine with fresh petrol in the spring.

When the boat has been launched you should open all hull bushings and check to ensure that there are no leaking hoses or connectors. The locations of bushings (through fittings) are shown in section 5. Bring your safety equipment back on board before setting out.

8 Lay-out

8.1 General lay-out

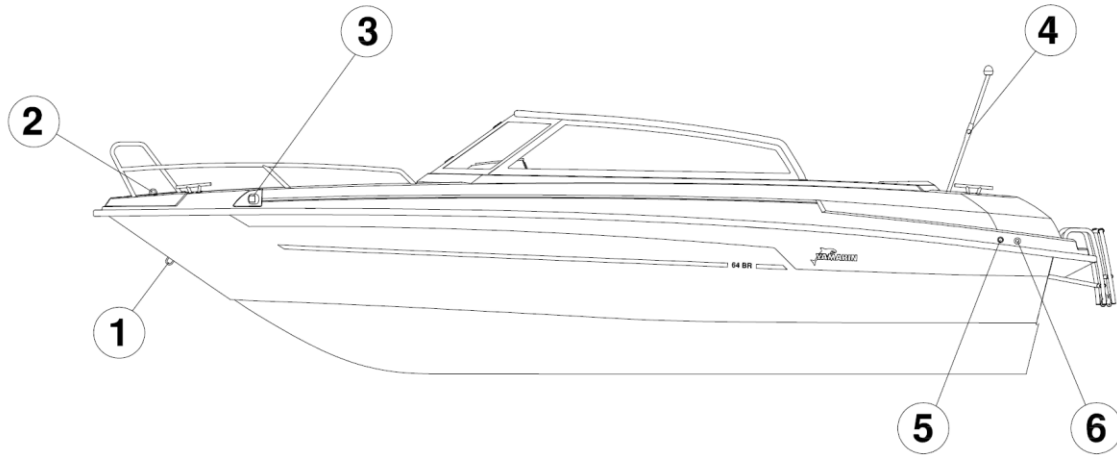

- | | |
|---------------------|-------------------------------|
| 1. Trailer hook | 4. Light mast |
| 2. Locking hook | 5. Fuel tank vent |
| 3. Navigation light | 6. Bilge pump through fitting |

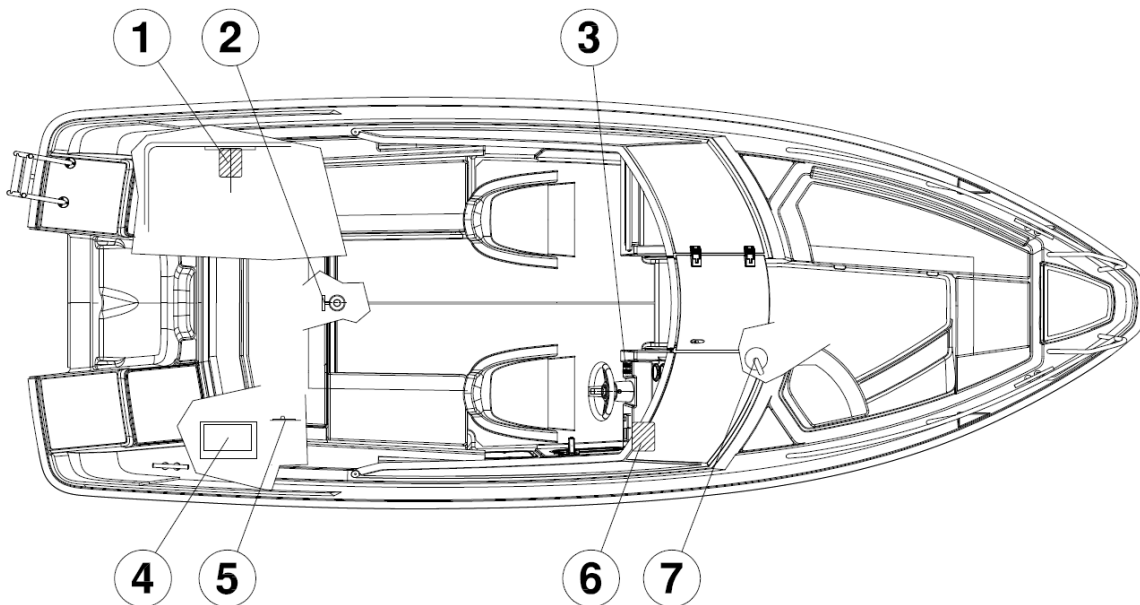

- | | |
|-------------------------------------|---------------------------------------|
| 1. Trim unit (accessory) | 5. Main power switch |
| 2. Rain water drainage valve | 6. Switches for trim tabs (accessory) |
| 3. Switchboard and fuse panel | 7. Fire extinguisher |
| 4. Battery (not standard equipment) | |

Image: General lay-out.

WARNING!

Handle the boat's hatches with care and watch your fingers and toes.

8.2 Fuel system

The boat has a built-in fuel tank. A fuel filter is installed in the fuel line. The filter must be changed at least once a year. When a new or removed filter has been mounted, the fuel line must be filled with a ball pump before starting the engine.

NOTE!

The condition of the fuel hoses must be inspected annually, and every effort should be made to prevent damage to them. Damaged fuel hoses must be replaced immediately. If you replace fuel hoses, make sure the new hoses have an ISO 7840 label.

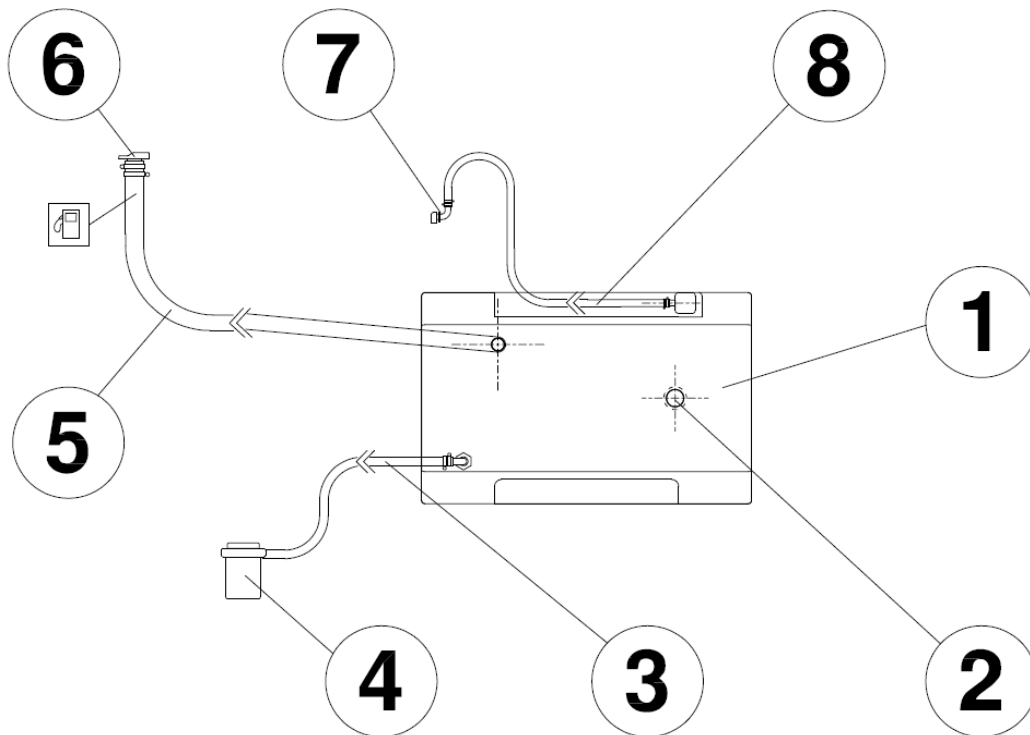

- | | |
|----------------------|----------------------------|
| 1. Fuel tank | 5. Fuel tank filling hose |
| 2. Fuel tank sensor | 6. Fuel refill |
| 3. Fuel feeding hose | 7. Fuel tank vent |
| 4. Fuel filter | 8. Fuel tank breather hose |

Image: Fuel system

The fuel refill is located on the left side of the engine well when viewed from the stern.

8.3 Steering system

The Yamarin Cross 64 BR has a hydraulic steering system.
The lengths of the hydraulics hoses are 5.5metriä x 2pcs.

NOTE! If you replace any component in the steering system, please note that all components must conform to the ISO 10592 standard and carry the CE mark.

8.4 Electrical system

The Yamarin Cross 64 BR electrical system contains the following main components:

1. Wire harness
2. Main power switch
3. Windscreen wiper
4. 3 switches
5. 2 pcs 12V power outlets
6. Navigation lights

In addition, the engine is an essential part of the boat's electrical system; it both generates and consumes power.

Switch off the main switch when leaving the boat for a long period of time. Remember also to switch off the main power switch before making any electrical installations.

If you connect or disconnect the battery, take care not to touch both battery terminals with a metal object at the same time. Please remember to observe caution in other respects as well if you have to charge the battery with a separate charger, charging the battery with excessive current creates an explosion risk.

Do not alter the onboard electric system or relevant drawings; alterations and maintenance work have to be carried out by a professional.

Wiring diagram

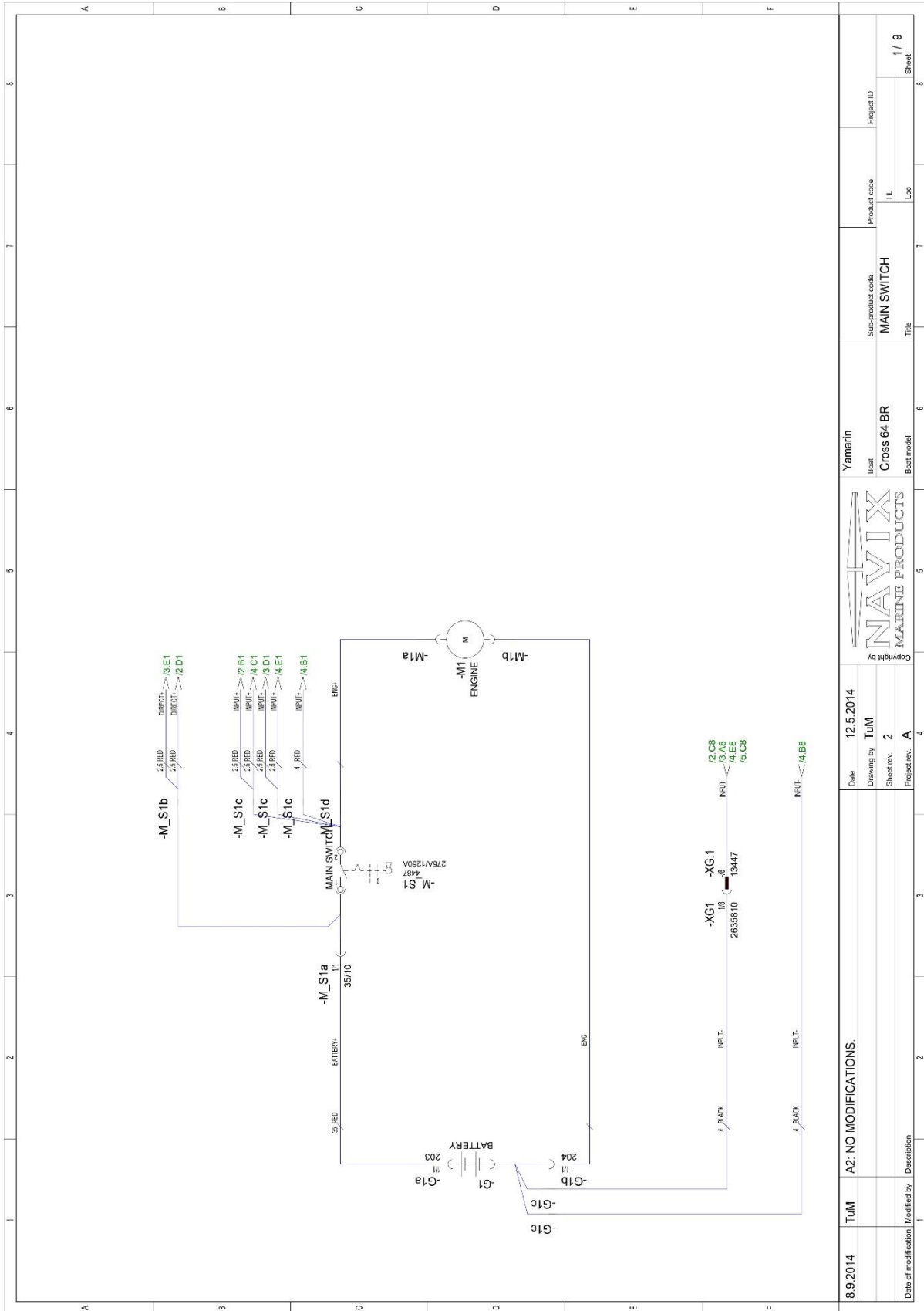

8.9.2014	TuM	A2: NO MODIFICATIONS.	Date	12.5.2014	Yamarin	Sub-product code	MAIN SWITCH	Product code	HL	Project ID	
			Drawn by	TuM	Boat	Cross 64 BR					
			Sheet rev.	2	Boat model						1 / 9
			Project rev.	A							Sheet
Date of modification		Modified by	Description								

