

JOBBER ADDICT 1.5

INSTALLATION GUIDE

Check WWW.JOBESPORTS.COM for other languages of this manual



Operating under the theory that an ounce of prevention is worth a pound of headaches, here is a helpful hint that will prevent any scratching during the Addict Tower assembly.

As you are removing the 4 arms and top center section out of the box, place masking tape strips around the top conjunction sections of the tubes that slide inside, and you will need to duplicate this process for both the front and rear. This will let you move and adjust the front and rear tower tubes without scratching the finish. But please use caution when sliding the sections together.

Keep the masking tape in place through the final assembly step, then, after drilling, remove the masking tape and your finish will be perfect.

Note that this installation guide is only a guideline. Each boat is different and improvisation is needed to mount your Addict tower on your boat.

We advise you to have your tower mounted by a professional who has experience in boat constructions and mounting other towers.

Contents of Box

Unpack the carton, there will be 7 sections:

Tower Mount set

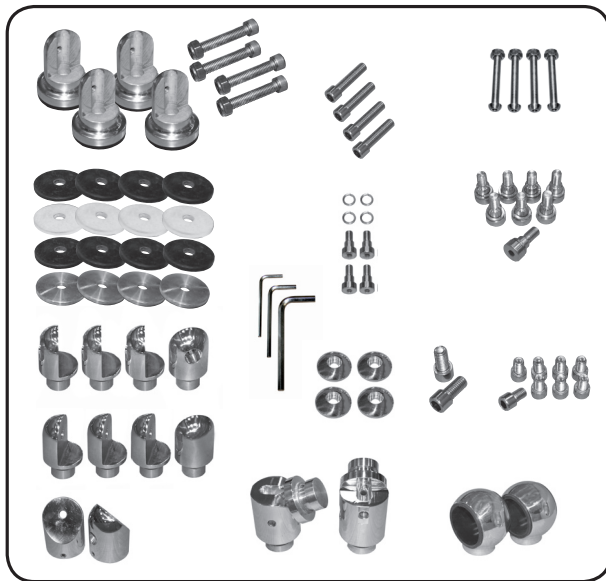

Tower Bars

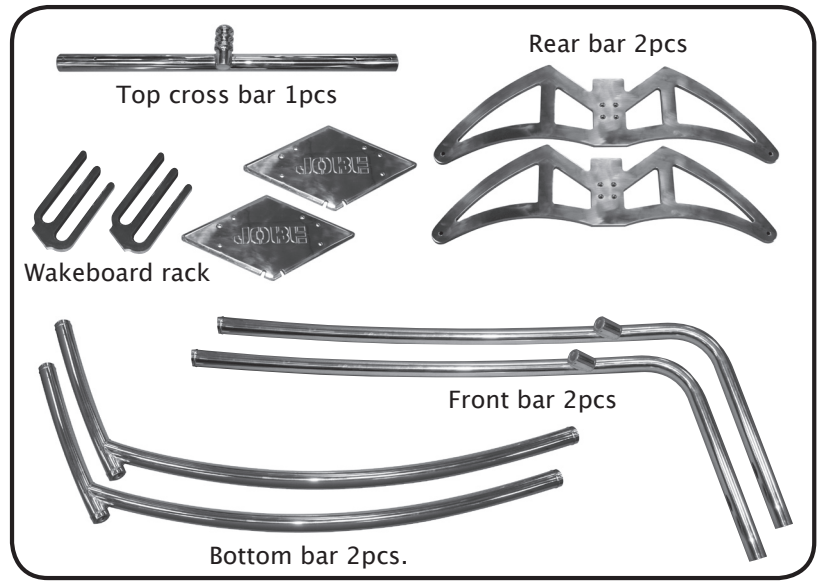

Prior to assembly, make sure all the required parts are present.

Necessities:

- Electric Drill
- Drill bit size 10 and 12
- Fork wrench
- Masking tape
- Chamfer drill bit

First decide if you want to do a top mount or a side mount.

Step 1

With masking tape cover the area where the mounting brackets will be placed. This should be done at all points where the tower will contact and the near surrounding area. This will help eliminate scratches to your boat while adjusting and measuring your tower attachment points.

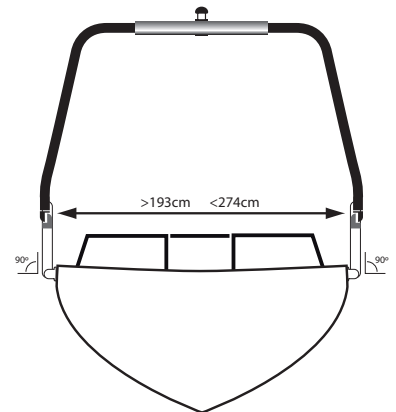

Mask mounting area

Step 2

Assemble the tower on the ground.

You will not be drilling any holes in the tower at this point.

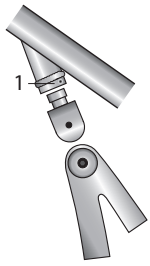

Connection A

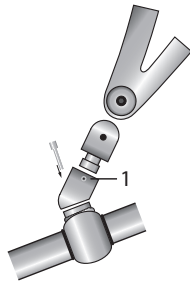

Connection B

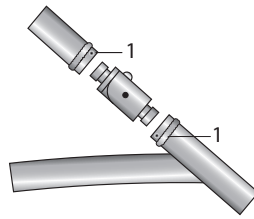

Connection C

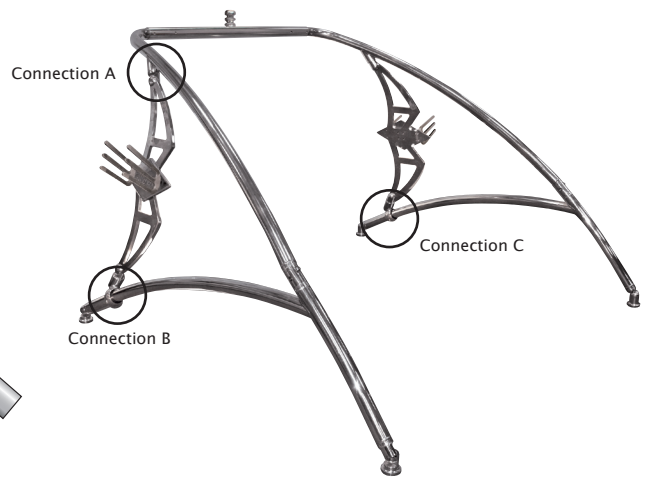

TIP: You can use threaded glue to prevent the small screws and central bolts from loosening during use. Frequently check/tighten the screws before use.

Step 3

Use the semi-assembled tower to determine the correct position on the boat. Hold the tower over the boat to see what it will look like. Bear in mind the height in the boat, the windscreen window, additional tower accessories, wiring etc etc... On boats that already have an existing ski pole (or preparation) the best thing to do is center the tower towing point above the existing towing point. When you have determined the correct position mark the position on the masking tape using the mounting brackets. !Make sure the mounting brackets are mounted completely level (on a flat spot)!



TIP: start +/- 20cm in front of the windscreen to determine the correct position. This for possible mirror mount on the tower.

Step 4

After marking one side you can mark the other side using the mounting brackets.



Step 5

Before drilling inspect the underside of these locations for obstructions such as wires or cables, also check the accessibility. You are now ready to drill the holes. For this use the drill bit size 12. After drilling the 4 holes, it is recommended to chamfer the holes using the chamfer drill bit, this to prevent the gelcoat from cracking.

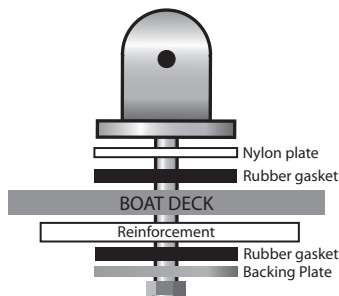

Step 6

IMPORTANT: When the BOAT DECK is less than 8mm thick we strongly advise to reinforce the mounting bracket with wood or fibreglass cloth. This to prevent stress on the boat which causes the gelcoat to crack. **WARRANTY DOES NOT COVER:** Any cracks or other damage to the gelcoat or boat because of mounting the tower.



Step 7

Install the bottom bars with the MOUNT SET. All feet are swivel and can work with various mounting angles. Note to mount the bottom bar vertical. When you fail to mount the bottom bar vertical, you will not be able to fold the tower. Snug the bolt but do not fully tighten at this time.

Step 8

Assemble the top tower on the bottom bars with MOUNT SET, all mounts are swivel to work with various mounting angles. Snug the bolts but do not tighten at this time.

NOTE: When you have a narrow boat you probably need to shorten the Top Cross Bar to make the tower fit to your boat.

Step 9

You are now ready to square up and center the loose assembly. Have someone stand in front of the boat and determine that the ski pylon is centered and the tower arms are symmetrical. Make any adjustments..

Drill through the predrilled holes in the center section from each side with 3/8" drill bit and install bolts and cap nuts.

One person will still be stabilizing the tower through this step.

Step 10

Assemble the two wakeboard racks on the tribal shaped rear bars. First assemble the two forks on the plate. Keep in mind that the forks should point up and make sure the logo and forks are facing the outside of the boat.

Tighten all hardware for completion of tower installation.

How to fold the tower

- I. Loosen the upper rear mounts (1)
- II. Remove bolts from lower rear mounts (2)
- III. Remove bolts from section (3)
- IV. Fold tower back to down position.

Care and Maintenance

- I. Be sure to check and tighten all fasteners and connections prior to every use.
- II. Be cautious when towing or driving under obstacles, low hanging structures or trees with your tower on.
- III. Use soap and water or general cleaners to clean your tower. Avoid abrasive materials that might scratch the tower's finish.
- IV. Always rinse tower after contact with salt (brackish) water.
- V. We strongly recommend to use an anodised tower when using your boat on salt (brackish) water.

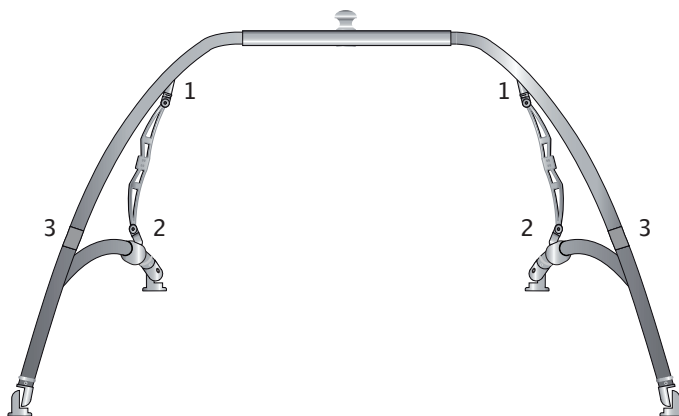

JOBE Addict Tower Warranty

Jobe Sports International warrants this product (not including other 3rd party accessories) against manufacturers defects. Anodizing and powder coated surfaces as well as all hardware corrosion are specifically excluded as their care and use cannot be controlled by Jobe Sports International. Any modifications or improper use shall void this warranty. Jobe Sports International is not responsible for personal injury or damage to the boat caused by the use of this tower. JOBE's obligation under this warranty shall not include any transportation charges or costs of installation or any liability for direct, indirect or consequential damages resulting from delay or improper installation. No dealer, retailer or manufacturer is the agent of Jobe Sports International and may not assume for Jobe Sports International any liability in connection with this warranty. This warranty is in lieu of all.

Distributed by:

Jobe Sports International
Heerwaardensestraat 30
6624 KK Heerwaarden
The Netherlands

WWW.JOBESPORTS.COM