

# JOIBE ADDICT

## LIGHT BAR INSTALLATION GUIDE



### NOTES ON INSTALLING AND USING YOUR NEW TOWER LIGHTS

- ◆ Tower lights will reach a high temperature when operating.  
Do not touch or wash the lights for 10 minutes after use.
- ◆ Use of a relay and switch is highly recommended.
- ◆ Towers lights are not intended for watersport activities at night.
- ◆ There are nearly infinite methods of wiring lights.  
Please contact a marine wiring specialist if you need assistance.  
We have provided the most complete information we have found within this document.
- ◆ It is highly recommended that you use a relay and a fuse with each set of lights.
- ◆ Use the insulating tape that is included in the box to insulate the wiring.
- ◆ Note that this installation guide is only a guideline. Each boat is different and improvisation is needed to mount your Addict accessory on your boat.

## Wiring Instructions

Using a relay with your switch in addition to the providing wiring, especially with multiple pairs of lights. These are readily available at auto parts stores and radio shack. Parts Express also has an excellent technical support department.

The relay will have terminal 87 providing power instead of the battery in the above diagram. Terminal 30 will then be run to the boat battery with a 25 amp inline fuse as shown below.

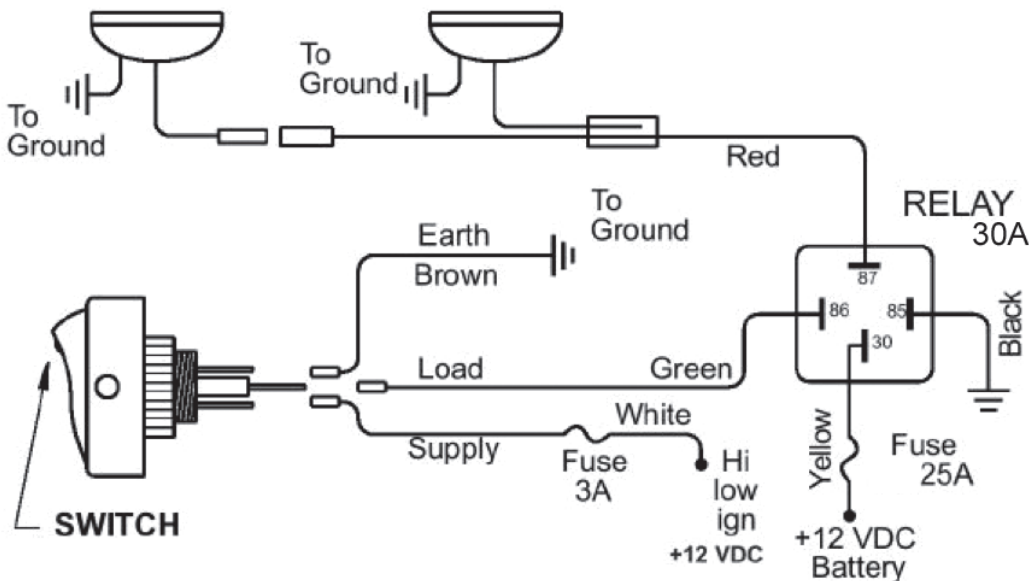

## Running Wires Through The Tower

The following is specific to running wires on a Addict Tower, otherwise consult your tower installation manual or provider for instructions on running wire inside your tower.

When you add speakers or lights to your Addict Tower, you can hide the wires inside of the legs of the tower as well as in the straight cross bar of the top section. Since the mating parts insert 1/2" inside each end of the rear leg you can drill 1" away from the weld lines. For the top section cross member you will need to place the hole 3" from the weld line to clear the rotating collar assembly. The hole size will depend on what size wire you are running and how many items you need to wire. The maximum hole size we recommend is 1/2" but normally smaller is all that is needed.

We recommend covering the exposed wiring with 3/8" or 1/2" wiring loom and electrical tape for a professional, watertight appearance.

## Care and Maintenance

- I. Be sure to check and tighten all fasteners and connections prior to every use.
- II. Be cautious when towing or driving under obstacles, low hanging structures or trees with your towers on.
- III. Use soap and water or general cleaners to clean. Avoid abrasive materials that might scratch the finish.
- IV. Always rinse lightbar & lights after contact with salt (brackish) water.

### JOBE Addict light bar Warranty

Jobe Europe warrants this product (not including other 3rd party accessories) against manufacturers defects. Anodizing and powder coated surfaces as well as all hardware corrosion are specifically excluded as their care and use cannot be controlled by Jobe Europe. Any modifications or improper use shall void this warranty. Jobe Europe is not responsible for personal injury or damage to the boat caused by the use of this tower. JOBE's obligation under this warranty shall not include any transportation charges or costs of installation or any liability for direct, indirect or consequential damages resulting from delay or improper installation. No dealer, retailer or manufacturer is the agent of Jobe Europe and may not assume for Jobe Europe any liability in connection with this warranty. This warranty is in lieu of all.

### Distributed by:

Sport en Recreatie Den Bol B.V.  
Heerewardensestraat 30  
6624 KK Heerwaarden  
The Netherlands

[WWW.WAKESKI.COM](http://WWW.WAKESKI.COM)