

DIMENSION (cm)

Lenght overall 270
 Lenght inside 187
 Wight overall 155
 Wingt inside 73

Engine max (HP) 10
 Engine recommended (HP) 6

CAPASITY

Passengers capacity 3
 Max loading capacity (kg) 400
 Boat weight (kg) 32

TUBE

Tube diametr (cm) 40
 No of chambers 3+2
 Tube volume (m*3) 0.6

Item No	Description	Qty	Note
1	Inflatable tube for C270	1	
2	V-shape bottom for C270	1	
3	Integral marine grade ply transom for C270	1	
4	4581 Airdeck for C270	1	
5	4139 Inflation-deflation valve BRAVO-2005	3	
6	4422 Motor plate extermal N3	1	
7	4410 Motor plate intermal 230x88	1	
8	4448 Pull up drain valve	1	
9	4591 Inflatable keel for C270	1	
10	4259 Towing eye, PVC	3	
11	4505 Wooden seat N3 grey	1	
12	4506 Wooden seat N4 grey	1	
13	4263 Rubbing strake, 80mm	1	
14	4262 Oarlock	2	
15	4102 Oar 160 cm lth rivert	2	
16	4257 Lifeline holder (end)	4	
17	4258 Lifeline holder (middle)	4	
18	4266 Lifeline, D 10mm	2	
19	4254 Wooden seat holder N1	4	
20	4256 Oar holder	2	
21	4250 PVC handle grey / grey insertion	1	

PROJECT/DESIGN/REVISED DRAWING NUMBER/REVISED DATE/REVISED LINES/REVISED PROFILES/REVISED		P-004	DRAWING SHEET BLOCK	DO NOT SCALE DRAWING	ADDRESS
NAME Kruglyak	SIGNATURE	DATE	Corvette C270A 1241		
NAME Drobysenko	SIGNATURE	DATE			
NAME Gribchenkov	SIGNATURE	DATE			
NAME M.P.	SIGNATURE	DATE			
MATERIAL	WEIGHT	SCALE 1:1	SHEET 1 OF 1		

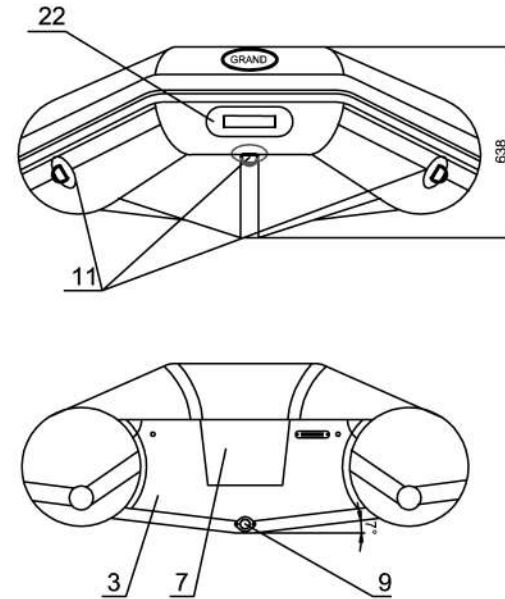
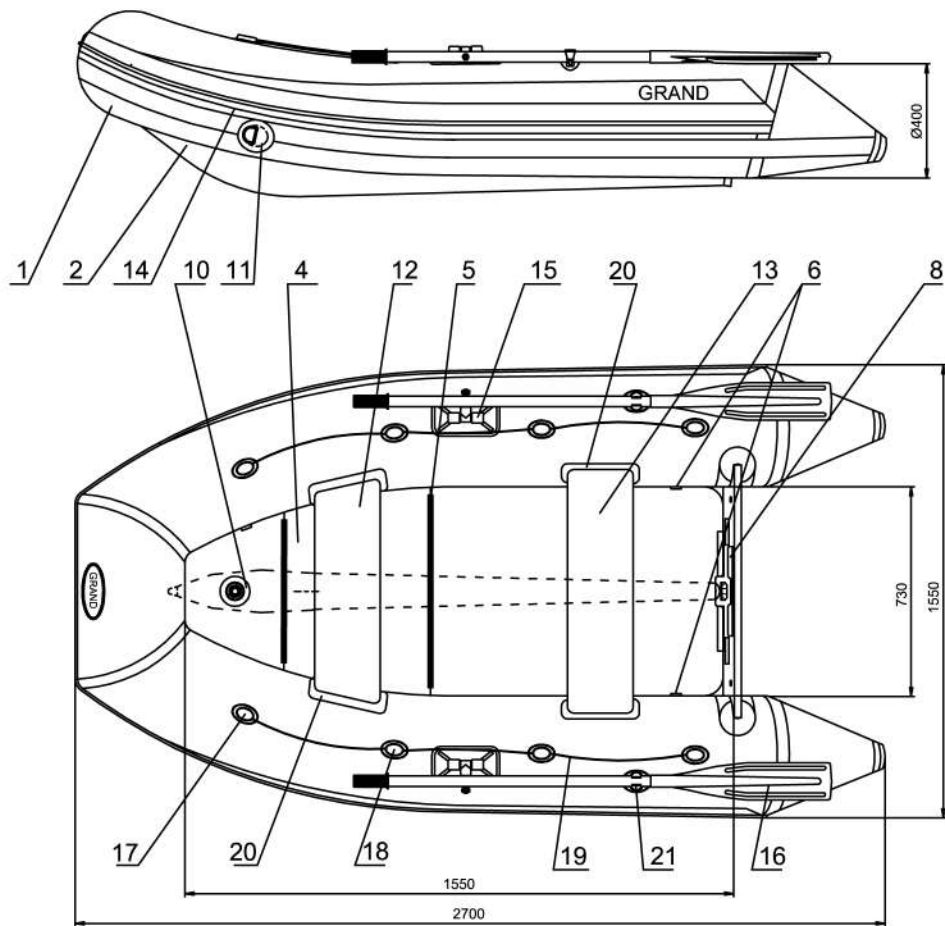

DIMENSION (cm)

Length overall 270
 Length inside 187
 Wight overall 155
 Wight inside 73

Engine max (HP) 10
 Engine recommended (HP) 6

CAPACITY

Passengers capacity 3
 Max loading capacity (kg) 400
 Boat weight (kg) 45

TUBE

Tube diametr (cm) 40
 No of chambers 3+1
 Tube volume (m³) 0.6

Item No	Description	Qty	Note
1	Inflatable tube for C270	1	
2	V-shape bottom for C270	1	
3	Integral marine grade ply transom for C270	1	
4	4561 Floorboards set for C270	1	
5	4571 Aluminum beams set for C270	1	
6	4139 Inflation-deflation valve BRAVO-2005	3	
7	4422 Motor plate extremal N3	1	
8	4410 Motor plate internal 230x86	1	
9	4448 Pull up drain valve	1	
10	4591 Inflatable keel for C270	1	
11	4259 Towing eye, PVC	3	
12	4505 Wooden seat №3 grey	1	
13	4506 Wooden seat №4 grey	1	
14	4263 Rubbing strake, 80mm	1	
15	4262 Oarlock	2	
16	4102 Oar 160 cm lth rivot	2	
17	4257 Lifeline holder (end)	4	
18	4258 Lifeline holder (middle)	4	
19	4266 Lifeline, D 10mm	2	
20	4254 Wooden seat holder N1	4	
21	4256 Oar holder	2	
22	4250 PVC handle grey / grey insertion	1	

DESIGNER		SIGNATURE		DATE		REVISION	
DESIGNER	Kruglyak	SIGNATURE		DATE		REVISION	
CHIEF	Drozhzhov	SIGNATURE		DATE		REVISION	
DESIGNER	Gerasimov	SIGNATURE		DATE		REVISION	
DATE		SIGNATURE		DATE		REVISION	
CORVETTE C270				1240			
SCALE 1:1				SHEET 1 OF 1			